

RESEARCH ARTICLE

TOPOLOGY OPTIMIZATION OF INTEGRATED COMBUSTION ENGINE PISTON USING FEA METHOD (CAE TOOLS)

S. Sathishkumar^{1*}, M. Kannan²¹Vel Tech-Avadi, Chennai-600062, Tamil Nadu, India²MAM College of Engineering, Trichy- 621105, Tamil Nadu, India*Corresponding Author E-mail: kssathishkumar.93@gmail.com

This is an open access article distributed under the Creative Commons Attribution License, which permits unrestricted use, distribution, and reproduction in any medium, provided the original work is properly cited.

ARTICLE DETAILS

ABSTRACT

Article History:

Received 27 September 2018
Accepted 25 November 2018
Available Online 7 January 2019

Topology optimization is a numerical approach that optimizes material arrangement within a given design space, for a given set of loads and periphery conditions such that the resulting layout meets a approved set of concert targets. Using topology optimization, engineers can find the best perception design that meets the design necessities. Topology optimization has been developed through the use of finite element methods of the analysis, and optimization techniques based on the method of moving asymptotes, genetic algorithms, optimality criteria method, level sets, and derivatives. Topology optimization is used at the idea level of the design process to appear at an intangible design plan that is then fine-tuned for concert and manufacturability. This thesis work correlated to the lay out optimization of internal combustion engine piston. Piston is one of the significant apparatus of engine. The multiple type of piston using through the automobile sectors. The various different type of piston is i) Equivalent lands thickness piston ii) Without crown piston (flat piston), iii) Without undercut piston, iv) With skirt land piston v) Dissimilar land thickness the analyzed this research work the Computer Aided Designing model initially created by CATIA, then Finite Element Analysis done by ANSYS.

KEYWORDS

Piston, topology optimization, CATIA V5 R20, ANSYS.

1. INTRODUCTION

CAE analysis tools offer the incredible advantage of enabling designers to think about virtually any molding decision without incurring the luxurious actual manufacturing of the machine module and machine moment associated to make machine component. The facility to try new designs or concepts on the computer gives the opportunity to reduce problems before establishment of production. Additionally, designers can hurriedly and easily decide the sensitivity of precise molding parameters on the quality and production of the final part [1,2]. The complex parts can be replicated easily by CAE tool Among engine components exposed to thermal effects, the piston is considered to be one of the most sternly stressed, where a high quantity of the heat transferred to a coolant fluid goes through it, this amount depends on the thermal conductivity (heat flux) of the materials engaged, the usual speed and the geometry of the piston [3,4]. Topology optimization has been hastily expanding with an enormous development in terms of theory, computational methods and applications [5]. It consists of a deterministic iterative optimization approach by recurring finite element analysis, analytically obtained sensitivities and design updates [6]. The conventional problems aspire for the optimal shape, size, and topology of an elastic body and its material properties under loading [7]. The geometry of the body is usually modeled using a raster depiction realizing the material distribution of the work piece. The classical example is to maximize the stiffness of load elastic body subject to a volume restriction but swiftly the method was extended to other objectives, like minimizing the weight or maximizing the essential Eigen value, and to other constraints, like buckling constraints, displacement constraints, design dependent loads and stress constraints [8-10]. Whereas a proficient approach to the problem of minimizing weight with respect to local material failure criterions is probably still to be suggested [11]. The curiosity of engineers and industry supported the growth of topology optimization significantly [12]. The design process followed during a typical industrial development process can be broken into the following distinct phases intangible design,

preliminary design, detailed design, and finally, testing. Ideally, the feedback of the simulations indicates only changes in the detailed design and frequent testing [13-15]. These loops are rather cheap in comparison to the situation if changes in the conceptual design are enforced. Then it could happen that the whole development process is relocated to its conceptual stage, which is usually expansive in both, time and costs, and endangers to delay the whole schedule [16]. Due to the fundamental role of the conceptual design phase topology optimization became a valuable computational tool for the basic layout [17]. In the later design phases, it can still be used to optimize small substructures to adapt the material properties of composite materials [18].

2. PISTON

A piston is a component of reciprocating IC-engines.

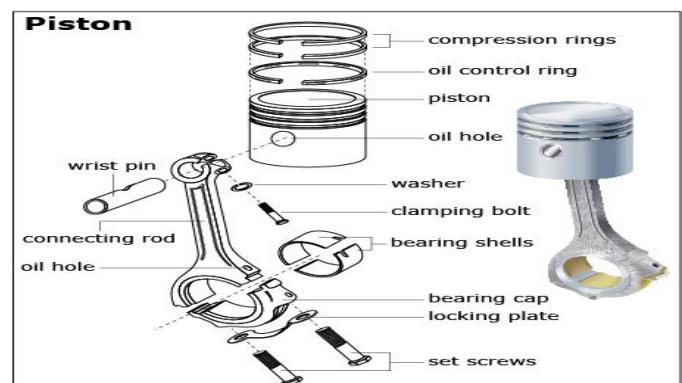

Figure 1: Piston Assembly

Based on a study, it is the moving component that is contained by a cylinder and is made gas-tight by piston rings [19]. Its purpose is to transfer force from expanding gas in the cylinder to the crankshaft via a piston rod [20]. Piston endures the repeated gas pressure and the inertial forces at work and this working condition may cause the fatigue damage of piston, such as piston side wear, piston head cracks [21]. So, there is a need to optimize the design of piston by considering various parameters [22]. In this research the parameters selected are thermal analysis of piston at various temperatures in different stroke. This analysis could be useful for design engineer for modification of piston at the time of design. In this paper we determine the stress calculation and we can find out the temperature distribution of various regions where chances of damage of piston are possible. From analysis it is very simple to optimize the design of piston. The main necessity of piston design is to measure the prediction of temperature distribution on the surface of piston which enables us to optimize the thermal aspects for design of piston at lesser cost. Most of the pistons are made of an aluminum alloy which has thermal expansion coefficient, 80% higher than the cylinder bore material made of cast iron. This leads to some differences between running and the design clearances. Therefore, analysis of the piston thermal behavior is exceptionally crucial in designing more efficient compressor. superior sealing of the piston with the cylinder is the basic criteria to design of the piston also to improve the mechanical efficiency and decrease the inertia force in high speed machines the weight of the piston also plays major role. To allow for thermal expansion, the diameter of the piston must be smaller than that of the cylinder. The needed clearance is calculated by estimating the temperature difference between piston and cylinder and considering the coefficient of thermal expansion of piston.

3. PISTON MATERIALS

3.1 Aluminum Silicon Alloy

The most universally used materials for pistons of I.C. engines are cast iron, aluminum alloy, forged aluminum, cast steel and forged steel [23]. The cast iron pistons are used for moderately rated engines with piston speeds below 6.9 m / s and aluminum alloy.

Pistons are used for highly rated engines running at higher piston speeds. It may be "noted"

1. Since the coefficient of thermal expansion for aluminum is about 2.56 times that of cast iron, therefore, a better clearance must be provided between the piston and the cylinder wall in order to prevent seizing of the piston when engine runs incessantly under heavy loads. But if excessive clearance is allowed, then the piston will develop 'piston slap' while it is cold, and this affinity increases with wear. The less clearance between the piston and the cylinder wall will lead to seizing of Piston [24].

2. Since the aluminum alloys used for pistons have high heat conductivity (nearly four times that of cast iron), therefore, these pistons ensure high rate of heat transfer and thus keeps down the maximum temperature difference between the center and edges of the piston head or crown [25].

3. Since the aluminum alloys are about three times lighter than cast iron, therefore, its mechanical strength is good at low temperatures, but they lose their strength (about 50%) at temperature above 325°C. Sometimes, the pistons of aluminum alloys are coated with aluminum oxide by an electrical method [26].

Table 1: Materials

S/No	Matrix Material	Reinforcement Material
1	Aluminium	Silicon

Table 2: Material Properties

S/No	Material	AlSi Alloy
1	Young's modulus [GPa]	90
2	Poisson's ratio	0.3
3	Thermal conductivity [W/m K]	155
4	Thermal expansion 10 ⁻⁶ [1/°C]	21
5	Specific heat [J/kg °C]	960
6	Density [kg/m ³]	2700

4. DESIGN CONSIDERATION FOR A PISTON

In designing a piston, the following Points should be taken into consideration [27]:

1. It should have enormous strength to withstand the high gas pressure and inertia forces.
2. It should have minimum mass to minimize the inertia forces.
3. It should form an effective gas and oil sealing of the cylinder.

4. It should provide adequate bearing area to prevent undue wear.
5. It should disperse the heat of combustion quickly to the cylinder walls.
6. It should have high speed reciprocation without noise.
7. It should be of sufficient rigid construction to withstand thermal and mechanical distortion.
8. It should have sufficient support for the piston pin or wrist pin.

5. DIMENSIONS OF PISTON

Table 3: Piston Dimensions

S/NO	PARAMETERS	DIMENSION
1	Piston Diameter	78
2	Piston Height	88
3	Skirt Height	58
4	Piston Inner Diameter	59.4
5	Radial Thickness	3.5

6. THE BOUNDARY CONDITIONS

One of the most important aspects to be considered during the analysis in order to achieve maximum accuracy is the selection of the boundary conditions [28]. The top surface of the piston is subjected to hot gases which take different values of temperature of gases T_g and convective heat transfer coefficient H_g for the different crank angles. The boundary condition for the present problem have been under taken to be as given below:

1. Temperature Level of piston head = 873K (273+300)
2. Temperature Level of piston ring = 493K (273+220)
3. Temperature Level of piston skirt = 463K (190+273)
4. Temperature Level of piston bottom portion = 343K (273+70)

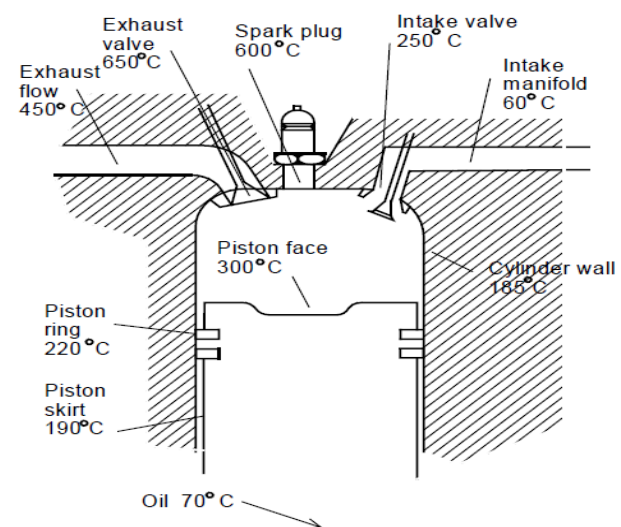

Figure 2: Boundary Conditions (Thermal Load)

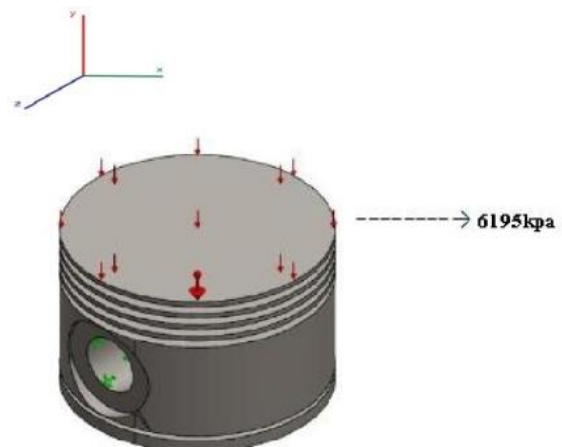

Figure 3: Boundary Conditions (Pressure Load)

Pressure load (6.195 Pa) is act the on the top portion of the piston, it is called piston head, pressure load will be varied according to engine specification now I have taken single cylinder four stroke engine piston.

6.1 CATIA V5R20 Model

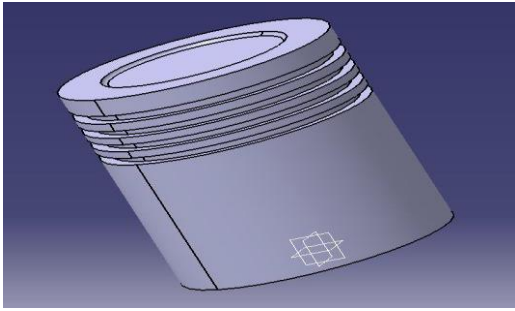

Figure 4: CATIA V5R20 Model

8.1 Same land thickness piston



Figure 8: Stress (Y direction)

6.2 Imported ANSYS Model

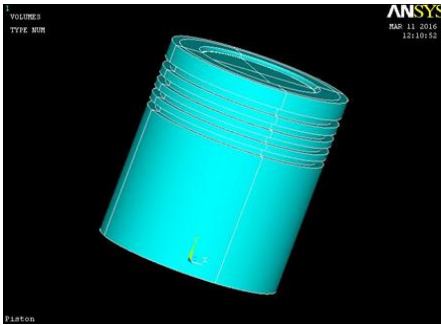

Figure 5: ANSYS Model

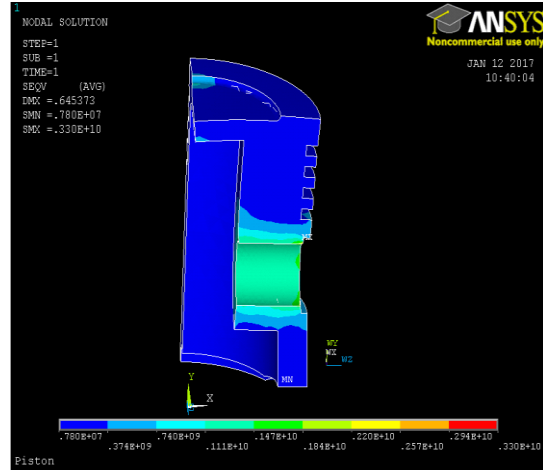

Figure 9: Equivalent stress (Von Misses stress)

7. ELEMENT DESCRIPTION

Solid 70 has a 3-D thermal conduction capability. The element has eight nodes with a single degree of freedom, temperature, at each node. The element is applicable to a 3-D, steady-state or transient thermal analysis. The element also can compensate for mass transport heat flow from a constant velocity field. If the model containing the conducting solid element is also to be analyzed structurally, the element should be replaced by an equivalent structural element

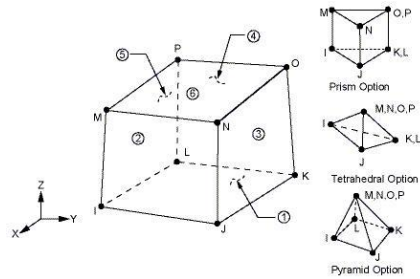

Figure 6: Element

8.2 Without undercut piston

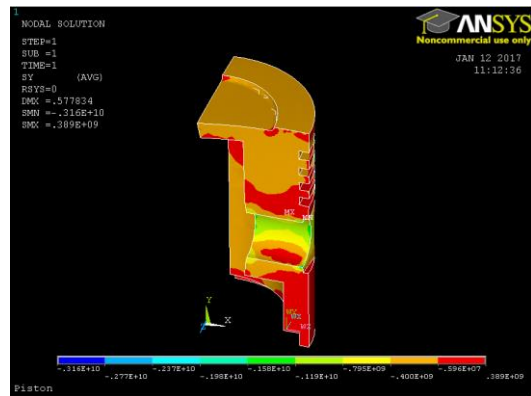

Figure 10: Stress (Y direction)

8. RESULT AND DISCUSSION

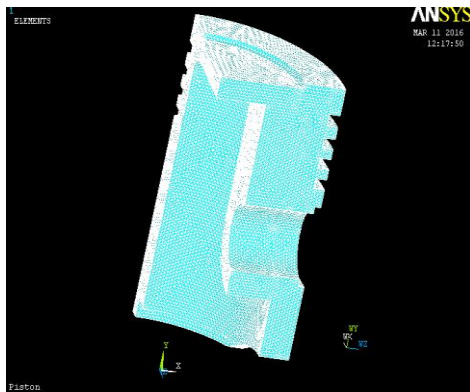

Figure 7: The model was divided in to four equal parts & one part is taken for analysis

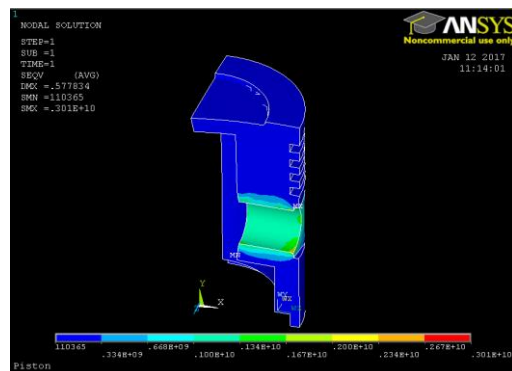

Figure 11: Equivalent stress (Von Misses Stress)

8.3 With skirt land piston

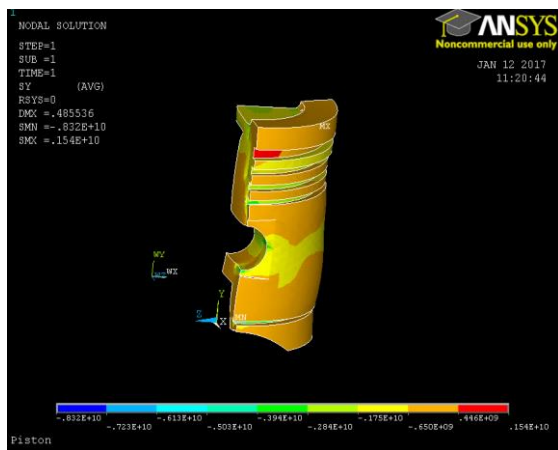

Figure 12: Stress (Y direction)

8.5 Without Crown Piston (Flat Piston)

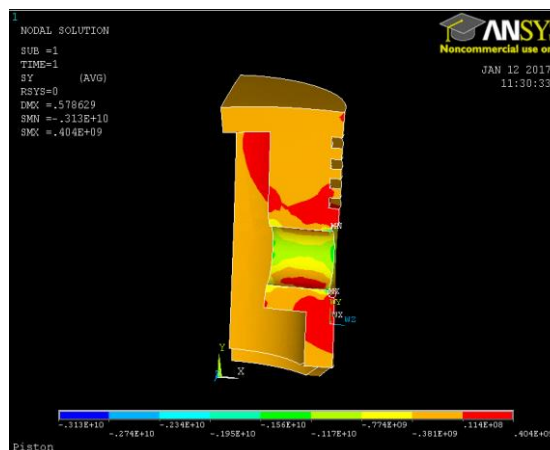

Figure 16: Stress (Y direction)

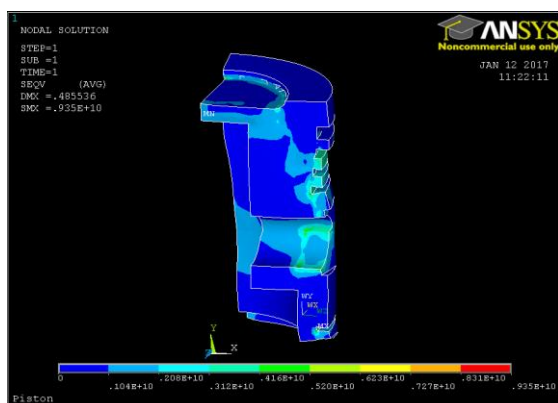

Figure 13: Equivalent stress (Von Mises Stress)

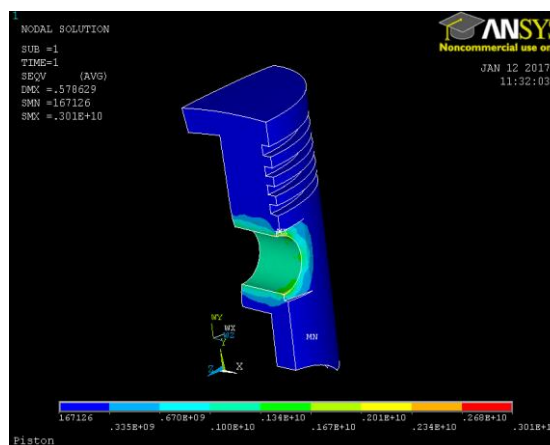

Figure 17: Equivalent stress (Von Mises Stress)

8.4 Different land thickness piston

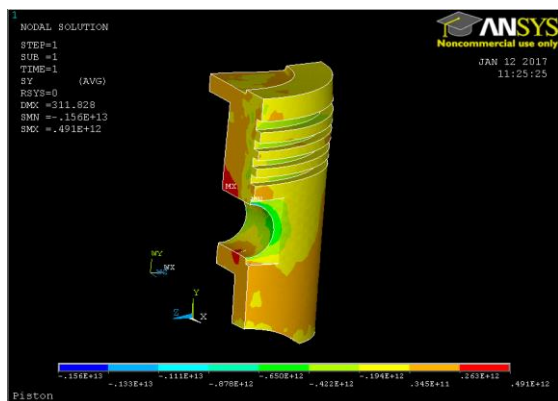

Figure 14: Stress (Y direction)

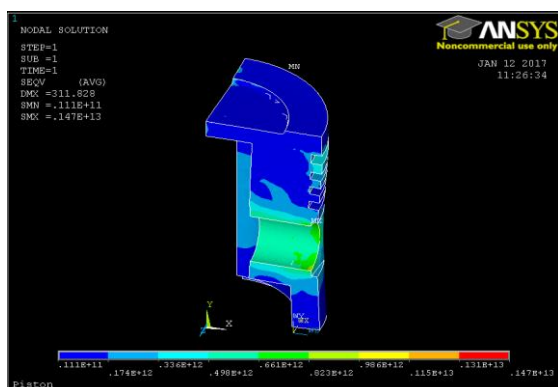

Figure 15: Equivalent stress (Von Mises stress)

Table 1: Result

Piston Type	Stress (Pa) (Y direction)	Von Mises Stress [Pa]
Same land thickness	725e6	330e7
Without undercut	389e6	301e7
With skirt land	154e7	935e7
Different land thickness	491e9	147e10
Without crown (flat piston)	404e7	301e7

9. CONCLUSION

It is concluded from the above study that using CATIA software design and modeling become easier. Here material used for piston is aluminum alloy because it is sustaining more temperature compare other material. The analysis done by using ANSYS software different type of piston analyzed here i) Same land thickness piston ii) Without undercut piston iii) With skirt land piston iv) Different land thickness v) Without crown piston it is called flat piston. To compare the different type of piston results the with crown & different land thickness piston is with stand the high thermal load and & high-pressure load so its comfortable design for piston. This type of piston using engines it's gives high efficiency& long life.

REFERENCES

- [1] Khurmi, R.S., Gupta, J.K. 2005. Machine Design Eurasia Publishing House. Ram Nagar, New Delhi.
- [2] Feng, S.S. 2014. An Experimental and Numerical Study of finned metal foam heat sinks under Impinging Air Jet Cooling, International Journal of Heat and Mass Transfer, 77, 1063–1074.
- [3] Haque, H.H. 2005. Effect of Superheating Temperatures on Microstructure and Properties of Strontium Modified Aluminium–silicon eutectic alloy. Journal of Materials Processing Technology, 162–163, 312–316

- [4] Calbureanu, M.X. 2013. The Finite Element Analysis of the Thermal Stress Distribution of a Piston Head" International Journal of Mechanics, 7(4), 467-474.
- [5] Srikanth Reddy, S. 2013. Thermal Analysis and Optimization of I.C. Engine Piston Using Finite Element Method, International Journal of Innovative Research in Science, Engineering and Technology, 2(12), 7834-7843.
- [6] Bhagat, A.R. 2012. Thermal Analysis and Optimization of I.C. Engine Piston Using Finite Element Method, International Journal of Modern Engineering Research (IJMER), 2(4), 2919-2921.
- [7] Vinay, V.K. Thermal Analysis of Piston for the Influence on Secondary motion, International Journal of Engineering Research and Applications (IJERA), 2248-9622, 3(3), 1402-1407.
- [8] Patel, B., Bhabhor, A. 2012. Thermal Analysis of a Piston of Reciprocating Air Compressor, IJAERS, 2249-8974, 73-75.
- [9] Harshavardhan, B., Mallikarjuna, J.M. 2015. Effect of piston shape on in-cylinder flows and air fuel interaction in a direct injection spark ignition engine-A CFD analysis. Energy, 81, 361-72.
- [10] Singh, A.P., Agarwal, A.K. 2012. Combustion characteristics of diesel HCCI engine: An experimental investigation using external mixture formation technique. Applied Energy, 99, 116-25.
- [11] Hou, L.G., Cui, C., Zhang, J.S. 2010. Optimizing microstructures of hypereutectic Al-Si alloys with high Fe content via spray forming technique. Materials Science and Engineering, 527, 6400-12.
- [12] Tutunchilara, S., Giviv, M.K.B., Haghpanahia, H., Asadi, P. 2012. Eutectic Al-Si piston alloy surface transformed to modified hypereutectic alloy via FSP. Materials Science and Engineering, 534, 557-67.
- [13] Warmuzek, M. 2004. Aluminum-Silicon Casting Alloys. ASM International, 1-6.
- [14] Dwivedi, D.K. 2001. The Institution of Engineers. India; 2001.
- [15] Lee, J.A. 2003. Cast aluminium alloy for high temperature applications. NASM/Marshall Space Flight Center (MSFC) Materials, 1-8.
- [16] Belov, N.A., Eskin, D.G., Avxentieva, N.N. 2005. Constituent phase diagrams of the Al-Cu-Fe-Mg-Ni-Si system and their application to the analysis of aluminium piston alloys. Acta Materialia, 53(17), 4709-22.
- [17] Hernandez, F.C.R., Sokolowski, J.H. 2006. Thermal analysis and microscopically characterization of Al-Si hypereutectic alloys. Journal of Alloys and Compounds, 419(1-2), 180-90.
- [18] Arsha, A.G., Jayakumar, E., Rajan, T.P.D., Antony, V., Pai, B.C. 2015. Design and fabrication of functionally graded in-situ aluminium composites for automotive pistons. Materials and Design, 88, 1201-9.
- [19] Yang, Y., Li, Y., Wu, W., Zhao, D., Liu, X. 2011. Effect of existing form of alloying elements on the micro hardness of Al-Si-Cu- Ni-Mg piston alloy, Materials Science and Engineering, 528(18), 5723-8.
- [20] Huang, Z.L., Wang, K., Zhang, Z.M., Li, B., Xue, H.S., Yang, D.Z. 2015. Effects of Mg content on primary Mg₂Si phase in hypereutectic Al-Si alloys. Transaction of Nonferrous Metals Society, China, 25, 3197-203.
- [21] Tutunchilara, S., Giviv, M.K.B., Haghpanahia, M., Asadi, P. 2012. Eutectic Al-Si piston alloy surface transformed to modified hypereutectic alloy via FSP. Materials Science and Engineering, 534, 557-67.
- [22] Zou, Q.C., Jie, J.C., Sun, J.L., Wang, T.M., Cao, Z.Q., Li, T.J., Zou, Q.C., Jie, J.C., Sun, J.L., Wang, T.M., Cao, Z.Q., Li, T.J. 2015. Effect of Si content on separation and purification of the primary Si phase from hypereutectic Al-Si alloy using rotating magnetic field. Separation and Purification Technology, 142, 101-7.
- [23] Medrano, F.J.T., Gruzleski, J.E., Samuel, F.H., Valtierra, S., Doty, H.W. 2008. Effect of Mg and Sr-modification on the mechanical properties of 319-type aluminium cast alloys subjected to artificial aging. Materials Science and Engineering, 480(1-2), 356-64.
- [24] Raghukiran, N., Kumar, R. 2015. Effect of scandium addition on the microstructure, mechanical and wear properties of the spray formed hypereutectic aluminium-silicon alloys. Materials Science and Engineering, 641, 138-47.
- [25] Sui, Y., Wang, Q., Wang, G., Liu, T. 2015. Effects of Sr content on the microstructure and mechanical properties of cast Al-12Si-4Cu-2Ni-0.8Mg alloys. Journal of Alloys and Compounds, 622, 572-9.
- [26] Rebba, B., Ramanaiah, N. 2014. Evaluation of mechanical properties of aluminium alloy (Al-2024) reinforced with molybdenum disulphide (MOS₂) metal matrix composites. 3rd International Conference on Materials Processing and Characterisation, Procedia Materials Science, India, 1161-9.
- [27] Gao, T., Zhu, X., Sun, Q., Liu, X. 2013. Morphological evolution of ZrAlSi phase and its impact on the elevated-temperature properties of Al-Si piston alloy. Journal of Alloys and Compounds, 567, 82-8.
- [28] Casari, D., Ludwig, T.H., Merlin, M., Arnberg, L., Garagnani, G.L. 2014. The effect of Ni and V trace elements on the mechanical properties of A356 aluminium foundry alloy in as-cast and T6 heat treated conditions. Materials Science and Engineering, 610, 414-26

